

Z.E.Ch. IGLOO product catalogue, group: Neutral counters

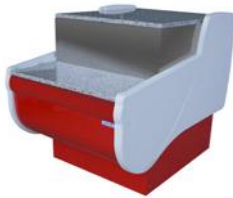

LADA SANTIAGO

Type: *LADA SANTIAGO*

1.2

ID:LS/SA1200



Management Service
ISO 9001: 2000

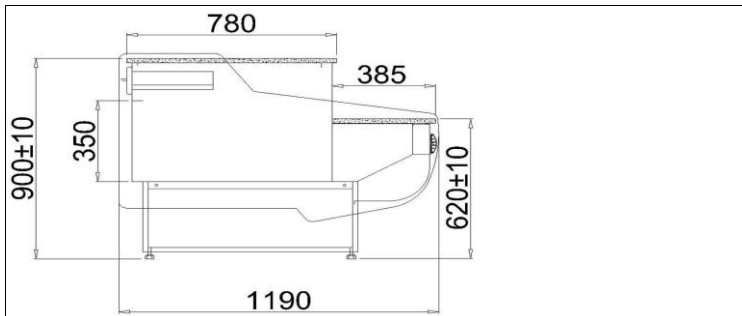

STANDARD

- front fender - color selection possible
- White-painted external body
- Small legs dedicated to level the counter
- work surface - granite, grey

Colour scheme

Base fender colors



Granite colors



ABS sides



Technical parameters

| | |
|---------------------------|----------|
| Length without sides [mm] | 1200 |
| Length with sides[mm] | 1280 |
| Depth[mm] | 1190 |
| Unit weight [mm] | 135 |
| Height [mm] | 900+/-10 |

Additional options add. cost

- side panels of ABS plastic - color selection possible
- work surface - granite, Balmoral
- front-line panel and/or base options colours

-Air temperature + 25 °C, air humidity 65% -Data alteration reserved * -only using IGLOO thermostat

Zakład Elektromechaniki Chłodniczej "IGLOO"

32-700 Bochnia, ul. Kazimierza Wielkiego 13

tel.: +48 14/ 662 19 10, fax: +48 14/ 662 19 12, e-mail:info@igloo.com.pl

